

THIS COPY IS PROVIDED ON A RESTRICTED BASIS AND IS NOT TO BE USED IN ANY WAY DETRIMENTAL TO THE INTERESTS OF PANDUIT CORP.

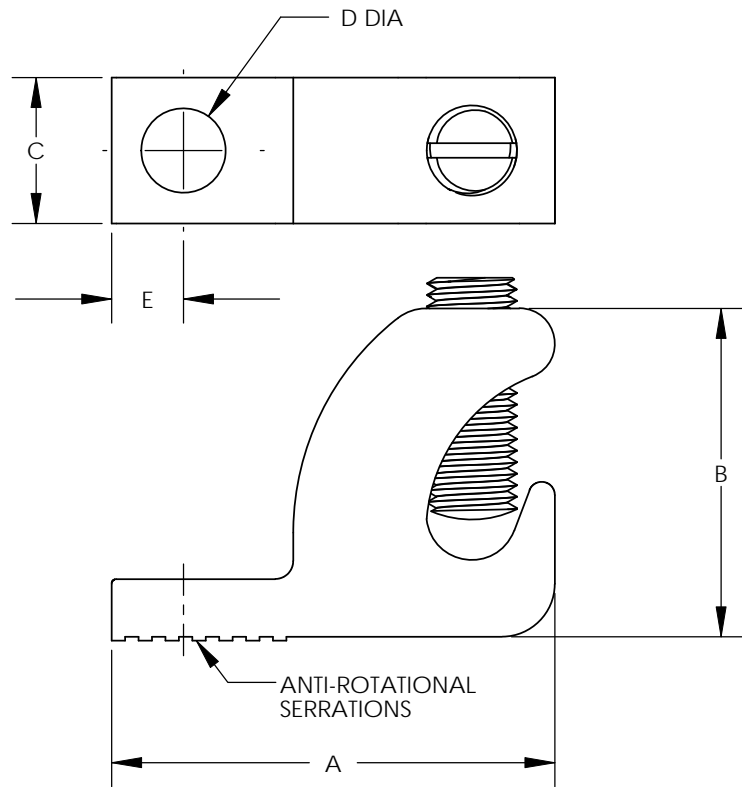

**NOTES:**

1. DIMENSIONS ARE IN INCHES. DIMENSIONS IN BRACKETS ARE MILLIMETERS.
2. UL LISTED & UL LISTED FOR USE IN CANADA.
3. DUAL RATED CU9AL FOR ALUMINUM OR COPPER CONDUCTORS (LIAC4-22-C, LIAS1/0-14-L, & LIAS250-56-Q ONLY).
4. RATED FOR DIRECT BURIAL APPLICATIONS (LICC4-22-C & LICC4-22TP-C ONLY).
5. ANTI-OXIDANT JOINT COMPOUND RECOMMENDED.
6. PACKAGE QTY:  
 Q = 25  
 L = 50  
 C = 100



**DB RATED**  
 (LICC4-22-C, LICC4-22TP-C ONLY)

PANDUIT PART NUMBER	MATERIAL	WIRE RANGE	SCREW TYPE	DIMENSIONS - IN [mm] +/- .02 [.5]					TIGHTENING TORQUE	PKG. QTY.
				A	B	C	STUD HOLE D DIA	E		
LICC4-22-C	COPPER	14 - 4 CU AWG	1/4-28 SLOTTED STAINLESS STEEL	1.16 [29.5]	.87 [22.1]	.39 [9.9]	#12 .22 [5.6]	.19 [4.7]	#14 - #10 = 20 IN-LB #8 = 25 IN-LB #6 - #4 = 35 IN-LB	100
LICC4-22TP-C	COPPER, TIN PLATED	14 - 4 CU AWG	1/4-28 SLOTTED STAINLESS STEEL	1.16 [29.5]	.87 [22.1]	.39 [9.9]	#12 .22 [5.6]	.19 [4.7]		100
LIAC4-22-C	ALUMINUM, TIN PLATED	14 - 4 CU/AL AWG	1/4-28 SLOTTED STAINLESS STEEL	1.06 [26.9]	.78 [19.8]	.39 [9.9]	#12 .22 [5.6]	.19 [4.7]		100
LIAS1/0-14-L	ALUMINUM, TIN PLATED	14 - 1/0 CU/AL AWG	3/8-24 SLOTTED STEEL, ZINC PLATED	1.50 [38.1]	1.10 [27.9]	.61 [15.5]	1/4" .27 [6.9]	.30 [7.6]	#14 - #10 = 35 IN-LB #8 = 40 IN-LB #6 - #4 = 45 IN-LB #3 - #1/0 = 50 IN-LB	50
LIAS250-56-Q*	ALUMINUM, TIN PLATED	6 - 250 kcmil CU/AL AWG	1/2-18 W/ 1/4" HEX KEY STEEL, ZINC PLATED	2.20 [55.9]	1.70 [43.2]	.80 [20.3]	5/16" .33 [8.4]	.40 [10.2]		200 IN-LB

\* UL PENDING

10J018AY-JC/01B

<b>PANDUIT CORP. TINLEY PARK, ILLINOIS</b>									
COPPER & ALUMINUM LAY-IN LUG CONNECTORS CUSTOMER DRAWING									
02	7/11	JHNU	RGB	REVISED PART NUMBER: LIAS1/0-14-L WAS LIAS10-14-L REVISED WIRE RANGE: 14-4 WAS 4-14	10J018AY-JC	RGB	RGB	UNLESS OTHERWISE SPECIFIED DIMENSIONAL TOLERANCES ARE: (.X) ± (.XXX) ± (.XX) ± .02 [.5] ANGLES ± 1°	UNLESS OTHERWISE SPECIFIED, ALL DIMENSIONS ARE GIVEN IN INCHES, THIRD ANGLE PROJECTION
01	7/11	JHNU	RGB	REVISED DIMENSIONS FOR LICC4-22, LICC4-22TP: A WAS 1.09, B WAS .75 REVISED NOTE 2, ADDED UL PENDING NOTE FOR LIAS250-56	10J018AY-JC	RGB	RGB		
00	2/11	JHNU	RGB	RELEASED TO PRODUCTION	10J018AY-JC	FLD	FLD	DRAWN BY: JHNU DATE: 2/11	SCALE: NONE
REV	DATE	BY	CHK	DESCRIPTION	ECN	-R	SUP	CHK'D: RGB	DRAWING NO / CAD FILE: 10J018AY-JC DWG SIZE: B